



Leading Open Source SOA

ebnm

WEBSOURCING

Easy-WSDL Toolbox



“In the beginning was the interface definition, and the interface definition language was WSDL”

Nicolas Salatgé, Phd, Research Engineer
at EBM WebSourcing
and WSDL enthusiast



- Problems
- State of the art
- WSDL1.1 vs WSDL2.0
- Proposed solution: easy WSDL toolbox
 - Presentation
 - How to use easy WSDL
 - Extensions: easy SAWSDL and easy WSDL4BPEL



- SOA softwares need to handle service descriptions → WSDL
- Two wsdl versions : WSDL 1.1 and WSDL 2.0
- Question
 - What is the WSDL version that I must integrate?
... WSDL1.1, WSDL 2.0 or both
- Examples: In SOA governance software like Dragon, it is necessary to handle these two formats.



- WSDL4J:
 - url: <http://wsdl4j.sourceforge.net/>
 - Handle WSDL 1.1: read/write/create
- Woden:
 - url: <http://ws.apache.org/woden/>
 - Handle WSDL 2.0: read/write/create
 - Can convert WSDL1.1 to WSDL2.0 using the W3C XSL Stylesheet
 - => Problem: Some of important information in WSDL1.1 are lost
 - Example: the “name” attribute in WSDL1.1 definition does not exist in WSDL2.0 description
- Commons problems:
 - Must cast binding to known the used binding
 - Impossible to get the types and elements defining in the schema
- Conclusion:
 - ➔ ***WSDL4J and Woden are not sufficient to handle all elements in service description.***



WSDL 1.1

WSDL 2.0

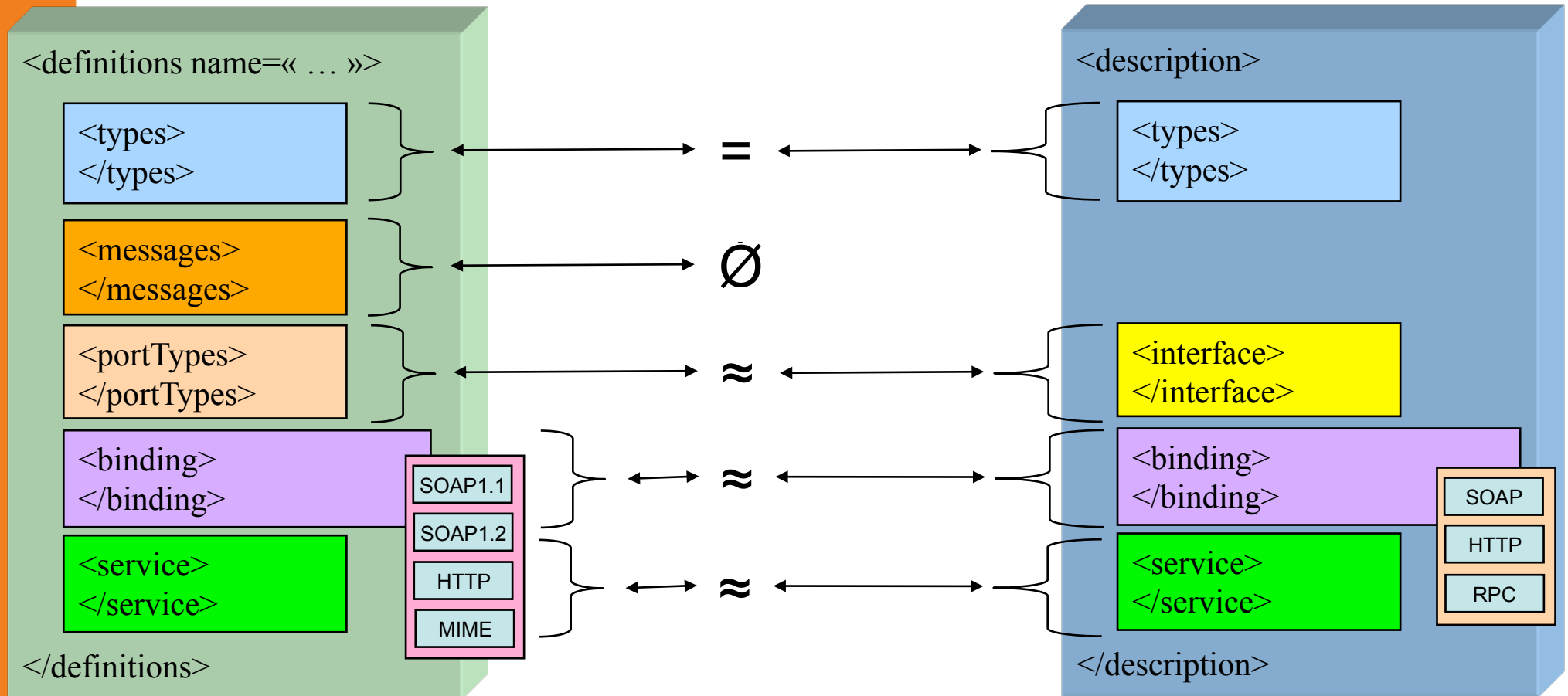



- Features:
 - Aggregate WSDL1.1 and WSDL 2.0 => but, have an orientation towards WSDL2.0
 - Example: When two identical concepts are two different names, we conserve the name of WSDL2.0 elements:
 - 1: definitions in WSDL1.1 and description in WSDL2.0 => Description interface in easy-WSDL
 - 2: portType in WSDL1.1 and interfaceType in WSDL2.0 => InterfaceType interface in easy-WSDL
 - Provide the most of used bindings in the two versions:
 - Note: Contrary to Wodden or WSDL4J, no cast=> the easy WSDL api provides all necessary methods (ex: getSOAP11Binding4WSDL11).
 - Allow to get elements and types defining in the schema (easy-schema)
 - Uniform API to read WSDL1.1 and WSDL2.0
 - Uniform API to write WSDL1.1 and WSDL2.0
 - Uniform API to create WSDL1.1 and WSDL2.0 (Under development)
 - Consistent conversion between WSDL1.1 to WSDL2.0 (Under development)
 - Can be extended: Easy SAWSDL and Easy WSDL4BPEL

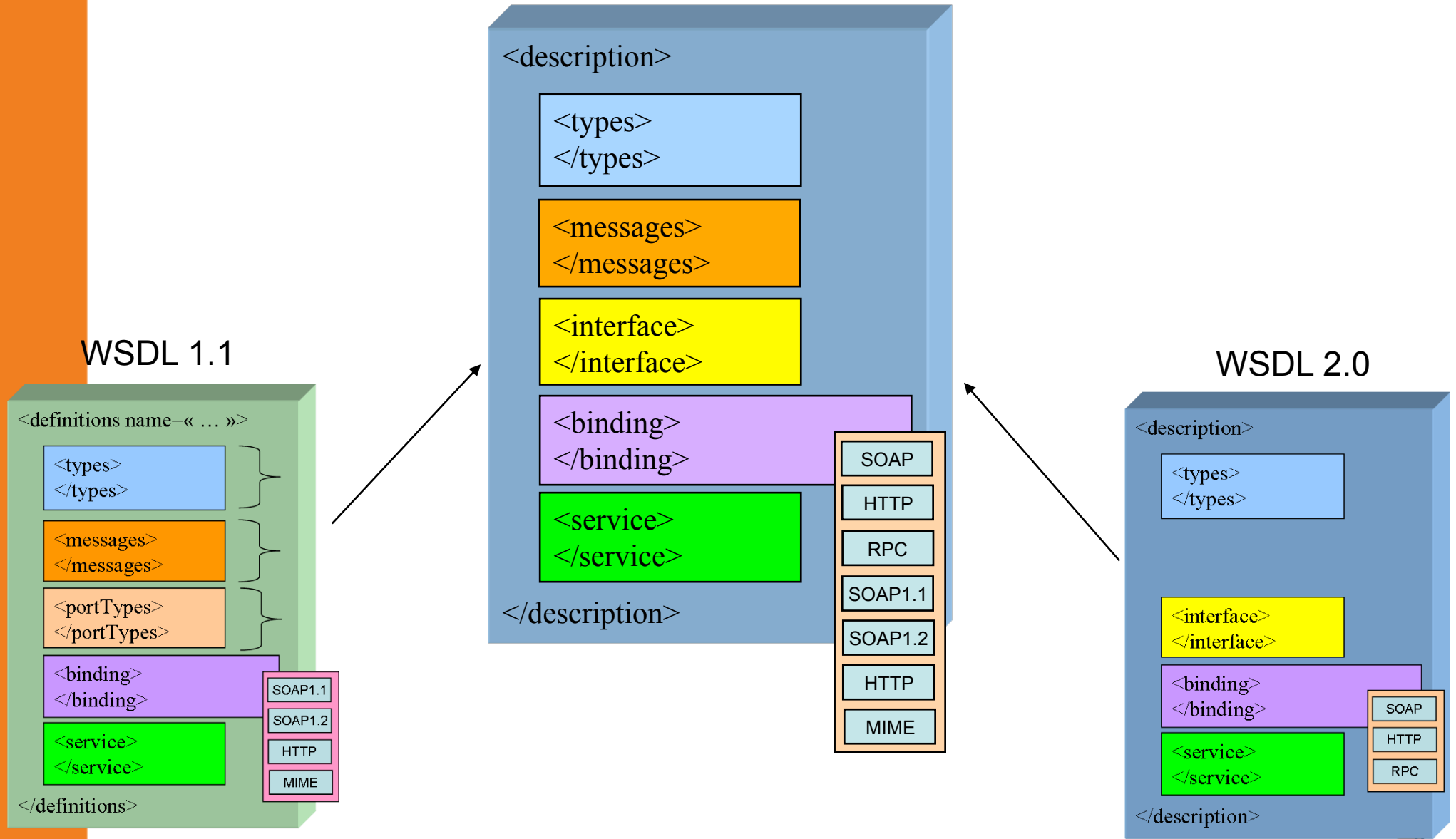



- *Read a WSDL 1.1 or 2.0 (uniform API):*

```
Description desc = WSDLFactory.newInstance().newWSDLReader().readWSDL(  
    new URI("http://api.google.com/GoogleSearch.wsdl"));
```

- *Write a WSDL 1.1 or 2.0 (uniform API):*

```
Document doc = WSDLFactory.newInstance().newWSDLWriter().getDocument(desc);
```

- *Create a WSDL 1.1 or 2.0 (uniform API):*

```
Description desc = WSDLFactory.newInstance().newDescription();
```



- SAWSDL specification:
 - ➔ Extends service description (WSDL 1.1 or WSDL 2.0) adding semantic annotations. These semantic annotations correspond to attributes attributes (ex: « modelReference ») added on any element in WSDL description (endpoint, service, ...etc.).
- Easy-SAWSDL extensions:
 - ➔ Extends easy-WSDL API adding methods in each interface. These added methods corresponding to SA-WSDL attributes (ex: getModelReference() method)



- *Read a SA-WSDL extension in WSDL 1.1 or 2.0 (uniform API):*

```
Description desc = SAWSDLFactory.newInstance().newSAWSDLReader().readSAWSDL(  
    new URI("./src/test/resources/descriptors/purchase.wsdl"));  
=> desc.getInterfaces().get(0).getModelReference();
```

- *Write a WSDL 1.1 or 2.0 with SA-WSDL extensions (uniform API):*

```
Document doc = SAWSDLFactory.newInstance().newSAWSDLWriter().getDocument  
(desc);
```

- *Create a WSDL 1.1 or 2.0 (uniform API):*

```
Description desc = SAWSDLFactory.newInstance().newSADescription();
```



- Easy-WSDL4BPEL extensions
 - => Allow to get or set partnerLink bpel extensions in service description.



- *Read a BPEL extension in WSDL 1.1 or 2.0 (uniform API):*

```
Description desc = WSDL4BPELFactory.newInstance().newWSDL4BPELReader  
().readWSDL4BPEL(  
    new URI("./src/test/resources/descriptors/purchase.wsdl"));  
=> desc.getPartnerLinkTypes().get(0).getRoles().get(0).getName();
```

- *Write a WSDL 1.1 or 2.0 with SA-WSDL extensions (uniform API):*

```
Document doc = WSDL4BPELFactory.newInstance().newWSDL4BPELWriter  
().getDocument(desc);
```

- *Create a WSDL 1.1 or 2.0 (uniform API):*

```
Description desc = WSDL4BPELFactory.newInstance().newWSDL4BPELDescription();
```



- Easy-WSDL has been tested on more of 50 services
 - Assert that values returned by easy-WSDL methods (actual value) are consistent with WSDL4J methods or Woden methods (expected value)
 - Plan to pass the W3C WSDL test suite so that the project can be registered on W3C Web Site
 - <http://dev.w3.org/2002/ws/desc/test-suite/Dashboard.html>
- Easy-WSDL is already integrated in SOA governance software: Dragon



?

<http://easywsdl.ow2.org>